

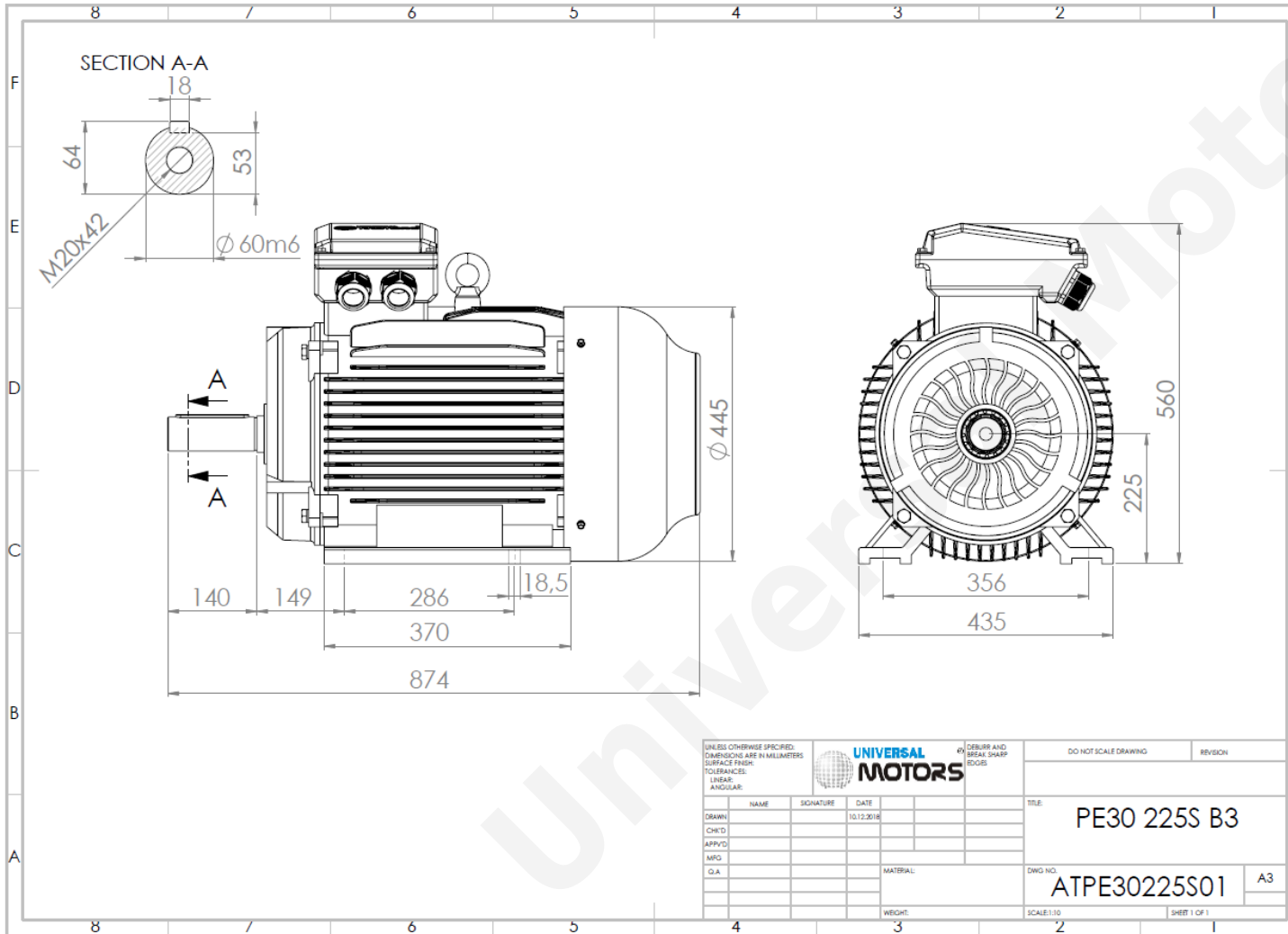

TECHNICAL DATA

Three Phase Electric Motors - Cast Iron Frame
 PE30 225S-8
 18.5 kW / 25 Cv
 730 RPM



Motor type:	PE30 225S-8
Output:	18.5 kW / 25 Cv
Speed (min ⁻¹):	730 RPM
Frequency:	50 Hz
Voltage:	400 V
Current:	39.0 A
Power factor (Cos ϕ):	0.76
Poles:	8
Insulation class:	F
Temperature rise Class:	B
Efficiency 50%:	88.7 %
Efficiency 75%:	90.4 %
Efficiency 100%:	90.1 %
Torque:	242 N.m
Tstarting/Tnominal:	1.9
Istarting/Inominal:	6.6
Tmaximum/Tnominal:	2.0
Noise:	73 Db(A)
Weight:	315 Kg
Bearing DE:	6313 C3
Bearing NDE:	6313 C3

Regime - S1

Altitude - 1000m

Environment Temperature - 40°C

CONTACTS:

UNIVERSAL MOTORS Tel: +351 252 299 080
 Rua de São Brás,745 Fax: +351 252 299 089
 4480-782 VILA DO CONDE Mail: geral@universalmotors.pt

* References applied only in the UK